



Application Note

Astra™ Machina Foundation Series Connection Of A Keypad

Abstract: This application note details the connection and operating of a Keypad by using a GPIO Expander.

Contents

1.	Overview.....	5
1.1.	Scope.....	5
1.2.	Hardware Items Required for Keyboard Support.....	6
1.3.	Interface Connection.....	7
1.3.1.	Functional Connection to Keypad Scan IC.....	9
1.3.2.	Functional Connection to I2C-GPIO Expander.....	10
1.3.3.	Functional Connection to SPI-GPIO Expander.....	12
1.3.4.	Functional Connection TCA8418-GPIO to Membrane 3x4 Keypad.....	14
2.	Software.....	15
2.1.	Keypad Scan (TCA8418) Software Support.....	15
2.2.	GPIO-based Keypad Driver.....	15
2.3.	SPI Expander Driver.....	15
3.	Function Description.....	16
4.	Hardware Considerations.....	17
5.	References.....	18
6.	Revision History.....	19

Downloaded by Anonymous () on 21 Jun 2026 04:02:52 UTC

List of Figures

Figure 1. Overview of Astra Machina Foundation Series.....	5
Figure 2. Astra Machina SL16xO RDK board 40-pin connector pin definition.....	7
Figure 3. Astra Machina SL261O RDK board 40-pin connector pin definition.....	8
Figure 4. Adafruit TCA8418 Breakout board.....	9
Figure 5. GPIO-Expander Breakout board.....	10
Figure 6. SPI-GPIO Expander Breakout board.....	12
Figure 7. Keypad Connection.....	14
Figure 8. Input Voltage of row-input.....	17

Downloaded by Anonymous () on 21 Jun 2026 04:02:52 UTC

List of Tables

Table 1. Adafruit TCA8418 interface connection on SL16x0 RDK.....	9
Table 2. Adafruit TCA8418 interface connection on SL2610 RDK.....	9
Table 3. GPIO Expander Interface connection on SL16x0 RDK.....	10
Table 4. GPIO Expander Interface connection on SL2610 RDK.....	11
Table 5. SPI-GPIO Expander Interface connection on SL16x0 RDK.....	12
Table 6. SPI-GPIO Expander Interface connection on SL2610 RDK.....	13
Table 7. Adafruit TCA8418 <-> 3x4 Keypad interface connection.....	14

Downloaded by Anonymous () on 21 Jun 2026 04:02:52 UTC

1. Overview

The Astra Machina Foundation Series offers evaluation-ready kits that facilitate quick and straightforward prototyping with the Synaptics SL-Series of embedded Linux® and Android™ processors. Featuring a modular design, these kits include interchangeable core compute modules, a standard I/O board and variety of daughter cards for connectivity, debugging, and various I/O configurations.

1.1. Scope

This application note is focused upon the connection of a keypad by means of either a GPIO Expander or a keypad scanner IC. The GPIO Expander provides I/O expansion using serial interface such as I2C or SPI. An alternative option is the connection of an I2C-controlled keypad scan IC.

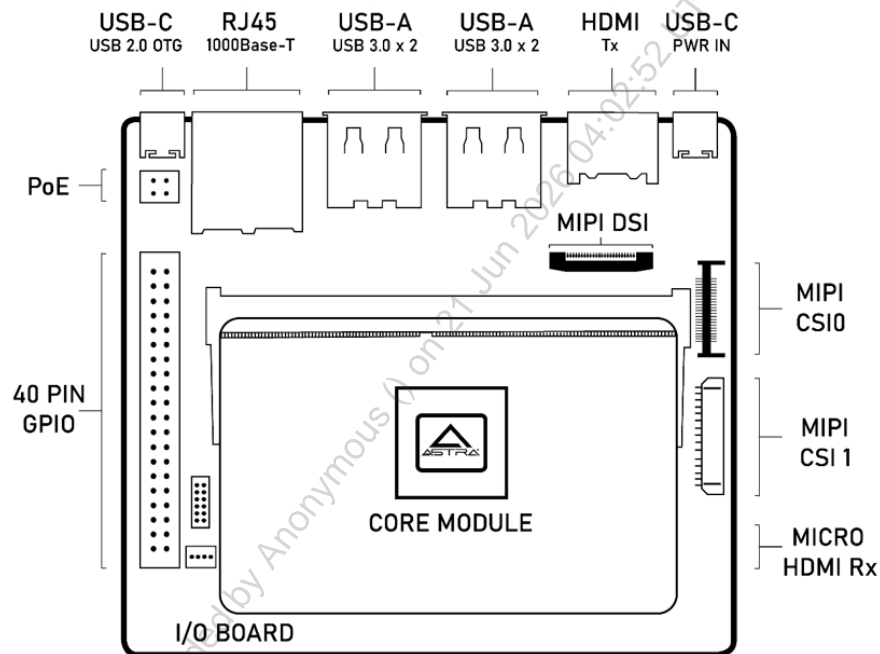

Figure 1. Overview of Astra Machina Foundation Series

1.2. Hardware Items Required for Keyboard Support

- [a] Synaptics Astra Machina SL16x0 evaluation board.
- [b] Keypad (for example: [4x4 Matrix Keypad](#) or [Membrane 3x4 Matrix Keypad](#) from Adafruit).
- [c] GPIO Expander (for example: [Onsemi FXL6408](#)). Demo boards are available from a variety of [companies](#).
 - 8-bit GPIO Expander
 - Interface Voltage: 1.65–3.6V
 - Interface Type: I2C

Optional

- [d] Texas Instrument I2C-Controlled Keypad Scan IC [TCA8418](#). Demo boards are available from [Adafruit](#).
 - Up to 8x10 keypad matrix driver
 - Interface voltage: 1.65–3.6V
 - Interface Type: I2C

Optional

- [e] Microchip 8-Bit SPI I/O Expander [MCP23S08](#). Demo boards are available from [Mikroe](#).
 - Up to 8x10 keypad matrix driver
 - Interface voltage: 1.65–3.6V
 - Interface Type: SPI

Downloaded by Anonymous () on 21 Jun 2026 04:02:52 UTC

1.3. Interface Connection

Synaptics Astra evaluation boards are equipped with a 40-pin header (2.54mm) which allows connection to the chip interface.

The definition of the SL16x0 IO 40-pin header is presented in Figure 2.



SL1620 RDK 40-Pin Header Definition					
I2S1_DO	40	●	●	39	GND
I2S1_BCLK	38	●	●	37	I2S1_MCLK
SPI2_SS3n	36	●	●	35	I2S1_LRCK
GND	34	●	●	33	CM_GPIO-EXP_0_7
GPIO47	32	●	●	31	GPIO48
GND	30	●	●	29	GPIO22
PDM_DI[1]	28	●	●	27	PDM_CLKIO
SPI2_SS1n	26	●	●	25	GND
SPI2_SSn	24	●	●	23	SPI2_CLK
GPIO55	22	●	●	21	SPI2_SDI
GND	20	●	●	19	SPI2_SDO
GPIO2	18	●	●	17	3.3V
PWM[2]	16	●	●	15	I2S1_DI
GND	14	●	●	13	TW1_SDA
CM_GPIO-EXP_0_2	12	●	●	11	TW1_SCL
URTO_RX	10	●	●	9	GND
URTO_TX	8	●	●	7	PWM[1]
GND	6	●	●	5	TWOA_SCL
5.0V	4	●	●	3	TWOA_SDA
5.0V	2	●	■	1	3.3V

Figure 2. Astra Machina SL16x0 RDK board 40-pin connector pin definition

The definition of the SL2610 IO 40-pin header is presented in Figure 3.

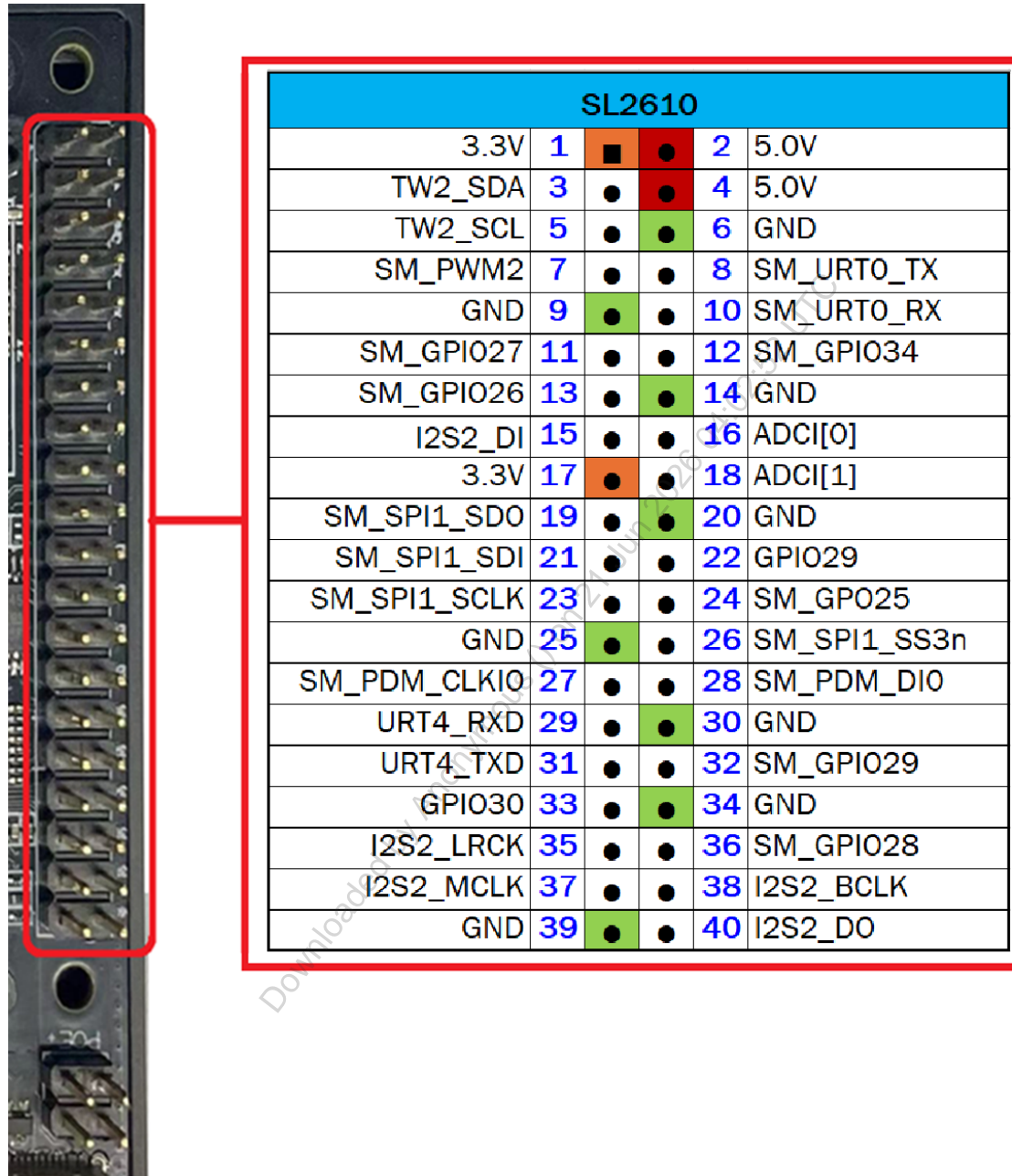

Figure 3. Astra Machina SL2610 RDK board 40-pin connector pin definition

1.3.1. Functional Connection to Keypad Scan IC

The TCA8418 Breakout board (see Figure 4) can easily be connected to the Astra 40-pin connector.

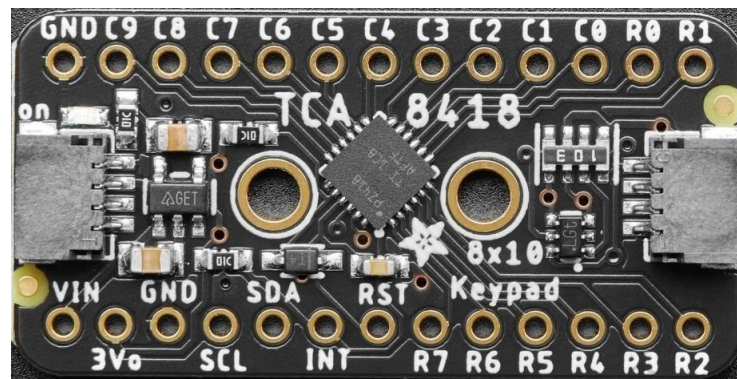

Figure 4. Adafruit TCA8418 Breakout board

Table 1 and Table 2 lists the required signals.

Table 1. Adafruit TCA8418 interface connection on SL16x0 RDK

Name	Description	Astra Pin #	Name
VIN	Power Supply input	2/4	5.0V
SCL	I2C clock signal	3	TWOA_SCL
SDA	I2C data signal	5	TWOA_SDA
GND	Power Ground	6,9,14,20, 25,30,34,39	GND
INT	Open-drain active low interrupt output	31	GPIO48
RST	Active-low reset input	32	GPIO47
CO-C9	Column pins of keypad matrix	Connect to keypad	
RO-R7	Row pins of keypad matrix		

Table 2. Adafruit TCA8418 interface connection on SL2610 RDK

Name	Description	Astra Pin #	Name
VIN	Power Supply input	2/4	5.0V
SCL	I2C clock signal	3	TW2_SCL
SDA	I2C data signal	5	TW2_SDA
GND	Power Ground	6,9,14,20, 25,30,34,39	GND
INT	Open-drain active low interrupt output	22	GPIO29
RST	Active-low reset input	33	GPIO30
CO-C9	Column pins of keypad matrix	Connect to keypad	
RO-R7	Row pins of keypad matrix		

1.3.2. Functional Connection to I2C-GPIO Expander

An alternative option is to connect a GPIO Expander and implement a keypad scanner via SW.

For demonstration purposes a 4x4 keypad scanner matrix is used with the following demo board (see Figure 5).

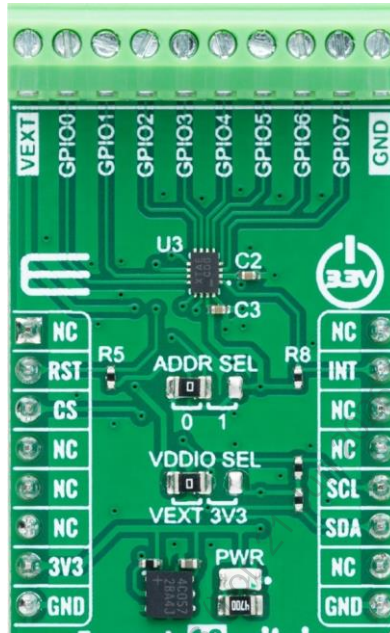

Figure 5. GPIO-Expander Breakout board

Table 3 and Table 4 shows the connection of the I2C bus and other relevant signals.

Table 3. GPIO Expander Interface connection on SL16x0 RDK

Name	Description	Astra Pin #	Name
3V3	Power Supply input	1	3.3V
SCL	I2C clock signal	3	TWOA_SCL
SDA	I2C data signal	5	TWOA_SDA
GND	Power Ground	6,9,14,20, 25,30,34,39	GND
INT	Open-drain active low interrupt output	31	GPIO48
RST	Active-low reset input	32	GPIO47
GPIO0-7	GPIO pins used for keypad matrix 4x4	Connect to keypad	

Table 4. GPIO Expander Interface connection on SL2610 RDK

Name	Description	Astra Pin #	Name
3V3	Power Supply input	1	3.3V
SCL	I2C clock signal	3	TW2_SCL
SDA	I2C data signal	5	TW2_SDA
GND	Power Ground	6,9,14,20, 25,30,34,39	GND
INT	Open-drain active low interrupt output	22	GPIO29
RST	Active-low reset input	33	GPIO30
GPIO0-7	GPIO pins used for keypad matrix 4x4	Connect to keypad	

Downloaded by Anonymous () on 21 Jun 2026 04:02:52 UTC

1.3.3. Functional Connection to SPI-GPIO Expander

Another option is to use an SPI based GPIO expander, such as the below Microchip GPIO expander (see Figure 6).

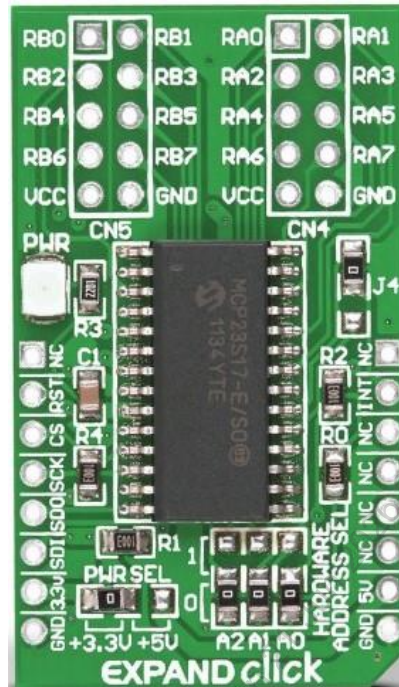

Figure 6. SPI-GPIO Expander Breakout board

Table 5 and Table 6 shows how to connect the SPI bus and other relevant signals.

Table 5. SPI-GPIO Expander Interface connection on SL16x0 RDK

Name	Description	Astra Pin #	Name
3V3	Power Supply input	1	3.3V
CS	SPI Chip Select	24	SPI2_SSO
SCK	SPI Clock	23	SPI2_CLK
SDO	SPI Data Output	21	SPI2_SDI
SDI	SPI Data Input	19	SPI2_SDO
GND	Power Ground	6,9,14,20, 25,30,34,39	GND
INT	interrupt output, configurable as active high, active-low or open-drain	31	GPIO48
RST	Active-low reset input	32	GPIO47
RAO-7 (RBO-7)	I/O Expander pins used for keypad matrix 4x4	Connect to keypad	

PWRSEL select the voltage reference for the I/O. It should be set to +3.3V.

Table 6. SPI-GPIO Expander Interface connection on SL2610 RDK

Name	Description	Astra Pin #	Name
3V3	Power Supply input	1	3.3V
CS	SPI Chip Select	26	SM_SPI1_SS3n
SCK	SPI Clock	23	SM_SPI1_CLK
SDO	SPI Data Output	21	SM_SPI1_SDI
SDI	SPI Data Input	19	SM_SPI1_SDO
GND	Power Ground	6,9,14,20, 25,30,34,39	GND
INT	interrupt output, configurable as active high, active-low or open-drain	22	GPIO29
RST	Active-low reset input	33	GPIO30
RAO-7 (RBO-7)	I/O Expander pins used for keypad matrix 4x4	Connect to keypad	

PWRSEL select the voltage reference for the I/O. It should be set to +3.3V.

1.3.4. Functional Connection TCA8418–GPIO to Membrane 3x4 Keypad

A keypad like the Adafruit 3x4 can be connected to the GPIO-expander as illustrated in Table 7.

Table 7. Adafruit TCA8418 <-> 3x4 Keypad interface connection

TCA8418 Breakout Name	Description	Keypad Pin #
CO-C3	Column pins of keypad matrix	5-7
RO-R4	Row pins of keypad matrix	1-4

Figure 7 displays the keypad pinout numbering.

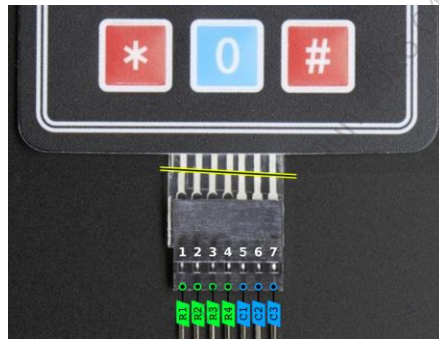

Figure 7. Keypad Connection

2. Software

2.1. Keypad Scan (TCA8418) Software Support

A Linux driver for the TCA8418 is available from the [Linux driver repository](#).

The I2C address used by the breakout board is 0x34.

2.2. GPIO-based Keypad Driver

Linux supports several [GPIO based keypad scan drivers](#).

2.3. SPI Expander Driver

The [Linux repository](#) includes a driver for the MCP23S08.

Downloaded by Anonymous () on 21 Jun 2026 04:02:52 UTC

3. Function Description

This chapter gives a brief overview of how a keyboard scanner works in general.

Typically, the keypad columns are driven as open-drain drivers¹. This prevents output contention, that is, if more than one key is being pressed at the same time.

When a key press is detected, an interrupt is sent to the CPU and the row input register can be read to determine which key has been pressed. While the platform is waiting for a key press, the software can set all the columns to active (low) so that any key press will cause an interrupt without the software having to continue scanning the keypad matrix.

In the first phase, the keystroke detection phase, it is checked whether a key has been pressed. This is done by setting all column outputs to low. The row pins are configured as inputs connected to pull-ups.

A key press is detected by sampling the logic level of the input lines. When a key is pressed, the row input is sampled as low. If no key is pressed, the input remains high due to the pull-ups.

In addition to determining the key position, the second phase involves key debouncing. This is done to prevent a single key press from being detected multiple times due to the key bouncing. Debouncing is accomplished by waiting to see if the previously detected key remains closed.

Once the debounce criterion is met, the driver searches for the key by scanning the keyboard matrix. The driver activates one column driver at a time and reads the input row signals.

If it reads a low, the corresponding key code can be derived from the column-row mapping.

¹ If the open-drain driver is not supported, the output should be switched to input direction.

4. Hardware Considerations

For a key closure to be detected, it is necessary that the respective pin is driven below the maximum low level input voltage (V_{IL}) specified in the datasheet. The value depends on the pull-up resistance and the keypad resistance (including track resistance). This can be calculated using the following formula.

$$R_{pull-up} > R_{sw} \times (V_{CC}/V_{IL} - 1)$$

V_{OL} is assumed to be 0V because the output drive current consumption will be very low.

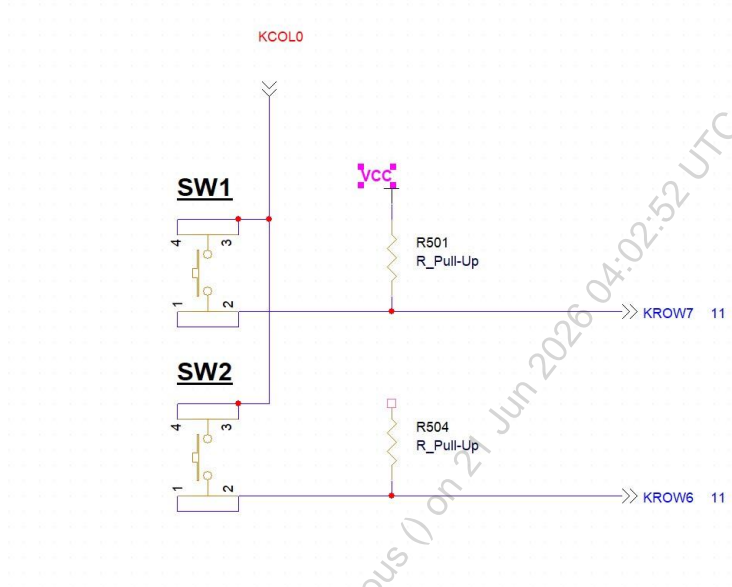

Figure 8. Input Voltage of row-input

5. References

- *Astra Machina Foundation Series Quick Start Guide* (PN: 511-001404-01)
- *Astra Machina SL1620 Developer Kit User Guide* (PN: 511-001407-01)
- *Astra Machina SL1640 Developer Kit User Guide* (PN: 511-001405-01)
- *Astra Machina SL1680 Developer Kit User Guide* (PN: 511-001403-01)
- *Astra Machina SL2610 Developer Kit User Guide* (PN: 511-001453-01)
- Onsemi datasheet FXL6408
- Microchip datasheet MCP23S08
- Texas Instrument datasheet TCA8418
- Onsemi I2C-GPIO Expander breakout board
<https://www.mikroe.com/expand-16-click>
- Microchip SPI-GPIO Expander breakout board
<https://www.mikroe.com/expand-click>
- Adafruit TCA8418 GPIO Expander Breakout
<https://www.adafruit.com/product/4918>
- Adafruit 4x4 Matrix Keypad
<https://www.adafruit.com/product/3844>
- Adafruit Membrane 3x4 Matrix Keypad
<https://www.adafruit.com/product/419>
- Linux TCA8418 driver
https://github.com/torvalds/linux/blob/master/drivers/input/keyboard/tca8418_keypad.c
- Linux GPIO based Keypad driver
https://github.com/torvalds/linux/blob/master/drivers/input/keyboard/matrix_keypad.c
- Linux SPI Expander driver
<https://github.com/torvalds/linux/blob/master/drivers/pinctrl/pinctrl-mcp23s08.c>

6. Revision History

Revision	Description
A	Initial release.
B	Minor update to correct trademarking.
C	Minor update to trademarked items.
D	Added SL2610-related items throughout.

Downloaded by Anonymous () on 21 Jun 2026 04:02:52 UTC



Copyright

Copyright © 2025 Synaptics Incorporated. All Rights Reserved.

Trademarks

Astra Machina, SyNAP, Synaptics and the Synaptics logo are trademarks or registered trademarks of Synaptics Incorporated in the United States and/or other countries.

Android is a trademark of Google LLC. Linux is the registered trademark of Linus Torvalds in the U.S. and other countries. All other trademarks are the properties of their respective owners.

Contact Us

Visit our website at www.synaptics.com to locate the Synaptics office nearest you.

PN: 506-001598-01 Rev D

Notice

Use of the materials may require a license of intellectual property from a third party or from Synaptics. This document conveys no express or implied licenses to any intellectual property rights belonging to Synaptics or any other party. Synaptics may, from time to time and at its sole option, update the information contained in this document without notice.

INFORMATION CONTAINED IN THIS DOCUMENT IS PROVIDED "AS-IS," AND SYNAPTICS HEREBY DISCLAIMS ALL EXPRESS OR IMPLIED WARRANTIES, INCLUDING BUT NOT LIMITED TO ANY IMPLIED WARRANTIES OF MERCHANTABILITY AND FITNESS FOR A PARTICULAR PURPOSE, AND ANY WARRANTIES OF NON-INFRINGEMENT OF ANY INTELLECTUAL PROPERTY RIGHTS. IN NO EVENT SHALL SYNAPTICS BE LIABLE FOR ANY DIRECT, INDIRECT, INCIDENTAL, SPECIAL, PUNITIVE, OR CONSEQUENTIAL DAMAGES ARISING OUT OF OR IN CONNECTION WITH THE USE OF THE INFORMATION CONTAINED IN THIS DOCUMENT, HOWEVER CAUSED AND BASED ON ANY THEORY OF LIABILITY, WHETHER IN AN ACTION OF CONTRACT, NEGLIGENCE OR OTHER TORTIOUS ACTION, AND EVEN IF SYNAPTICS WAS ADVISED OF THE POSSIBILITY OF SUCH DAMAGE. IF A TRIBUNAL OF COMPETENT JURISDICTION DOES NOT PERMIT THE DISCLAIMER OF DIRECT DAMAGES OR ANY OTHER DAMAGES, SYNAPTICS' TOTAL CUMULATIVE LIABILITY TO ANY PARTY SHALL NOT EXCEED ONE HUNDRED U.S. DOLLARS.