



Application Note

Astra™ Machina Foundation SD and SDIO Host

Abstract: This application note details the guidelines for connecting and configuring an SD card with the SL1620, SL1640, and SL1680 RDK.

Contents

1.	Overview	5
1.1.	Scope	5
1.2.	Hardware Connection of SD Card on SL1620/SL1640 RDK	6
1.2.1.	SD card pin assignment.....	6
1.2.2.	SDIO structure of SL1620/SL1640 RDK.....	7
1.3.	Hardware Connection of SD Card on SL1680 RDK	8
1.4.	SD Card Configuration of SL1620 RDK.....	9
1.5.	SD Card Configuration of SL1640 RDK.....	9
1.6.	SD Card Configuration of SL1680 RDK.....	10
2.	References	11
3.	Revision History	12

Downloaded by Anonymous () on 21 Jun 2026 04:02:27 UTC

List of Figures

Figure 1. Overview of Astra Machina Foundation Series.....	5
Figure 2. SDIO connection of SL1620 and SL1640 RDK.....	7
Figure 3. SDIO connection of SL1680 RDK.....	8

Downloaded by Anonymous () on 21 Jun 2026 04:02:27 UTC

List of Tables

Table 1. SD card pin assignment with voltage	6
Table 2. SD card configuration of SL1620 RDK	9
Table 3. SD card configuration of SL1640 RDK	9
Table 4. SD card configuration of SL1680 RDK	10

Downloaded by Anonymous () on 21 Jun 2026 04:02:27 UTC

1. Overview

The SL16x0 RDK is a high-performance reference development kit designed for embedded systems, offering support for SD card peripherals to enable data storage and system expansion. The SD controller in the SL1620/SL1640 operates at a 1.8V I/O voltage; however, many SD cards support both 1.8V and 3.3V signaling. To ensure proper voltage compatibility and reliable communication, a level shifter is required to translate signals between the SL1620/SL1640 and the SD card. For SL1680, the SDIO Host supports both 1.8V and 3.3V signaling, so no level shifter is needed.

1.1. Scope

This application note focuses on the implementation of SD card connections with the SL1620/SL1640/SL1680 RDK. It provides detailed guidelines on hardware connections, voltage-level translation, and configuration to ensure reliable communication between the SD controller and SD card peripherals. The document is intended for system designers and engineers working with the SL1620/SL1640/SL1680 platform, enabling proper integration of SD card interfaces for data storage and expansion.

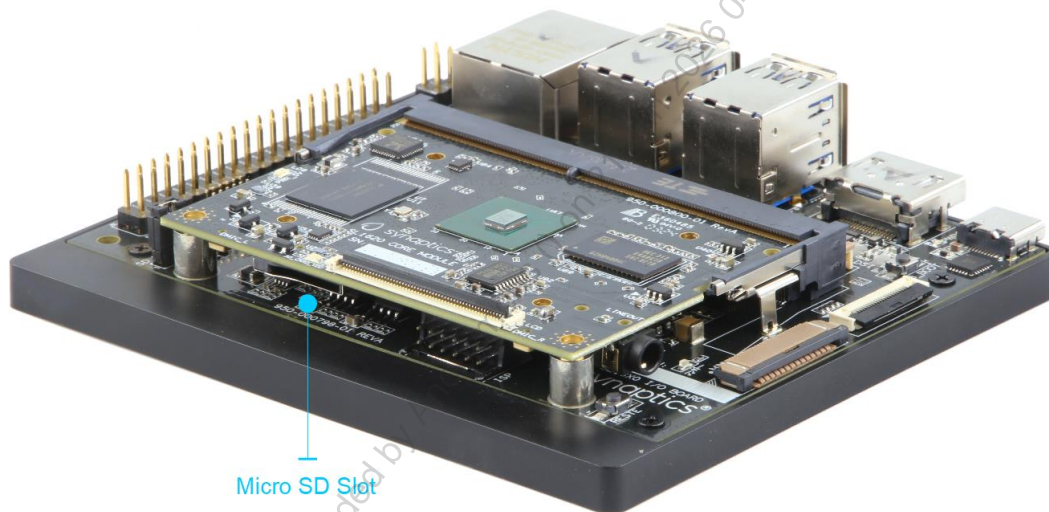

Figure 1. Overview of Astra Machina Foundation Series

SL1620, SL1640 and SL1680 RDK supports the following SD card speed modes:

- **Default Speed mode:** 3.3V signaling, frequency up to 25 MHz, up to 12.5 MB/sec
- **High Speed mode:** 3.3V signaling, frequency up to 50 MHz, up to 25 MB/sec
- **SDR12:** UHS-1 1.8V signaling, frequency up to 25 MHz, up to 12.5MB/sec
- **SDR25:** UHS-1 1.8V signaling, frequency up to 50 MHz, up to 25MB/sec
- **SDR50:** UHS-1 1.8V signaling, frequency up to 100 MHz, up to 50MB/sec
- **SDR104:** UHS-1 1.8V signaling, frequency up to 200 MHz, up to 100MB/sec
- **DDR50:** UHS-1 1.8V signaling, frequency up to 50 MHz, sampled on both clock edges, up to 50MB/sec

1.2. Hardware Connection of SD Card on SL1620/SL1640 RDK

1.2.1. SD card pin assignment

The pin assignments for operating the SD card in SDIO mode with a 4-bit data bus are shown in Table 1.

Table 1. SD card pin assignment with voltage

Pin #	Name	Description	Voltage Level
1	CLK	Clock	3.3V/1.8V
2	CMD	Command/Response	3.3V/1.8V
3	DAT0	Data Line 0	3.3V/1.8V
4	DAT1	Data Line 1	3.3V/1.8V
5	DAT2	Data Line 2	3.3V/1.8V
6	DAT3	Data Line 3	3.3V/1.8V
7	VDD	Supply voltage	3.3V
8	VSS	Ground	0V

- **Pull-Up Resistors:** External pull-up resistors are not required in the hardware design, as both the SL1620 and SL1640 feature internal pull-up resistors on the SDIO bus.
- **Power Supply:** The VDD pin of the SD card slot should be connected to a 3.3V power supply.
- **Level Shifter:** A level shifter is required for the SD bus because the SDIO signals of the SL1620/SL1640 operate at 1.8V only. Depending on the SD card operation mode, the SD bus voltage for CLK, CMD, and DAT[3:0] signals can be either 3.3V or 1.8V.

1.2.2. SDIO structure of SL1620/SL1640 RDK

Figure 2 illustrates the SDIO connection for the SL1620 and SL1640 RDK.

- **SDIO_MUX_SEL:** The SDIO host interfaces with both the SDIO Wi-Fi module and the SD card through an SDIO bus multiplexer (MUX). The software selects the active connection using the SDIO_MUX_SEL signal.
- **SDIO_VOL_SEL:** This signal controls the SD bus I/O voltage level, switching between 3.3V and 1.8V. For further details, refer to the CMD11 I/O voltage switching sequence in the SD card specification.
- **SDIO_PWR_ON:** This signal controls the power supply to the SD card, enabling the 3.3V VDD power.

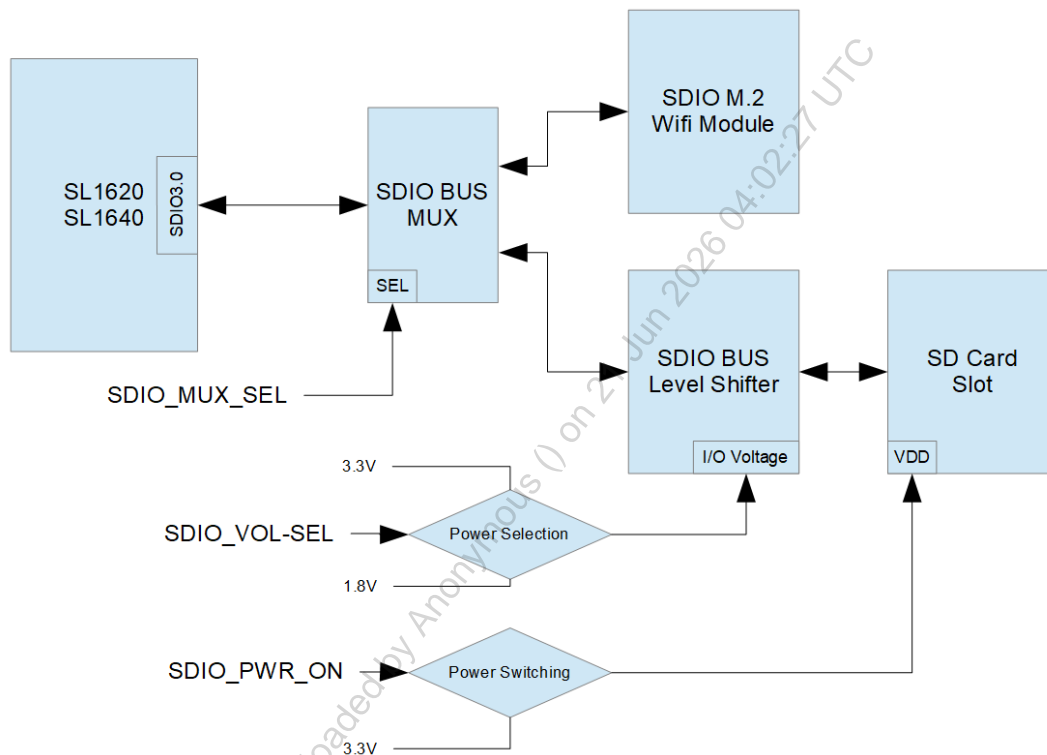

Figure 2. SDIO connection of SL1620 and SL1640 RDK

1.3. Hardware Connection of SD Card on SL1680 RDK

Figure 3 illustrates the SDIO connection for the SL1680 RDK. The SDIO Host on the SL1680 includes an internal feature for switching the SD bus voltage between 3.3V and 1.8V, eliminating the need for an external level shifter.

- **SDIO_MUX_SEL:** The SDIO host interfaces with both the SDIO Wi-Fi module and the SD card through an SDIO bus multiplexer (MUX). The software selects the active connection using the SDIO_MUX_SEL signal.
- **SDIO_PWR_ON:** This signal controls the power supply to the SD card, enabling the 3.3V VDD power.

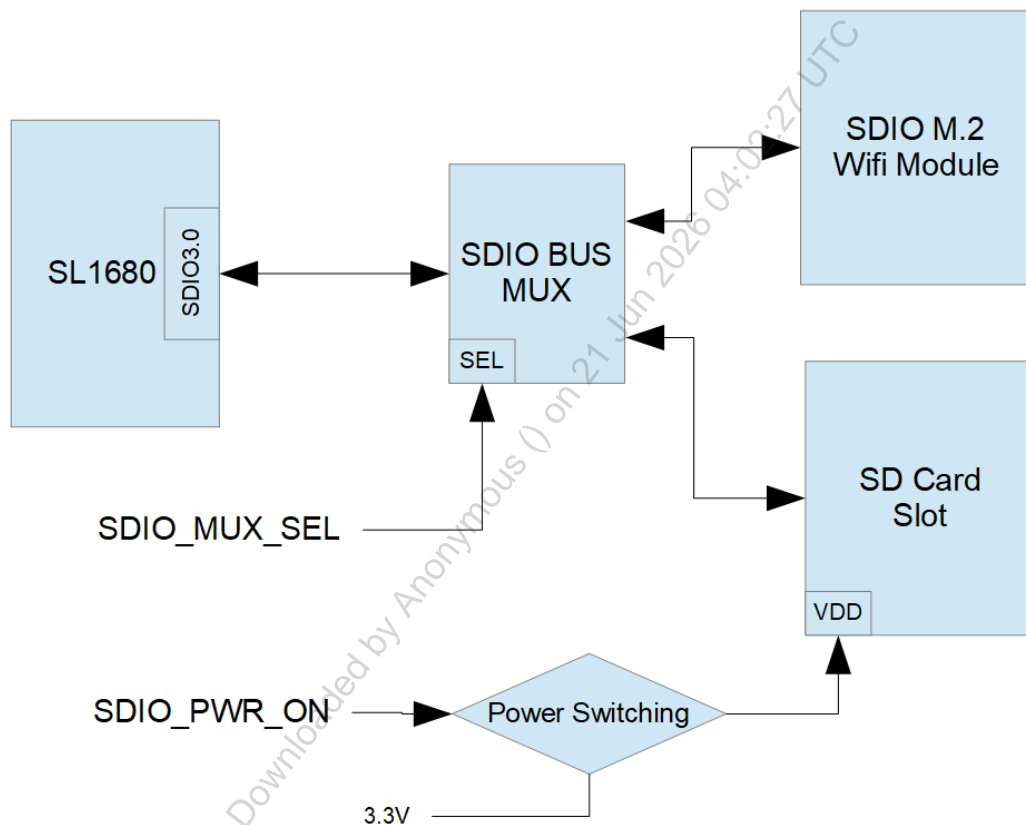

Figure 3. SDIO connection of SL1680 RDK

1.4. SD Card Configuration of SL1620 RDK

Table 2 lists the SD card related control signal configurations of SL1620 RDK.

Table 2. SD card configuration of SL1620 RDK

Signal #	Name	Description	Source
1	SDIO-MUX_SEL	0: Switch SDIO to M.2 WiFi 1: Switch SDIO to SD Card Slot	IOEXP: TW1 (0x43) GPIO0_0
2	SDIO_PWR_ON	0: Power OFF SD card slot 1: Power ON SD card slot	IOEXP: TW1 (0x44) GPIO1_4
3	SDIO_VOL-SEL	0: 1.8V 1: 3.3V	IOEXP: TW1 (0x44) GPIO1_6

1.5. SD Card Configuration of SL1640 RDK

Table 3 lists the SD card related control signal configurations of SL1640 RDK.

Table 3. SD card configuration of SL1640 RDK

Signal #	Name	Description	Source
1	SDIO-MUX_SEL	0: Switch SDIO to SD Card Slot 1: Switch SDIO to M.2 WiFi	SD card Slot CDn
2	SDIO_PWR_ON	0: Power OFF SD card slot 1: Power ON SD card slot	SOC_GPIO[48]
3	SDIO_VOL-SEL	0: 1.8V 1: 3.3V	SOC_GPIO[17]

SDIO_MUX_SEL is controlled by the **Card Detect (CDn)** pin of the SD card slot. When an SD card is inserted, **CDn** is pulled low, and the SDIO host automatically switches its connection to the SD card.

1.6. SD Card Configuration of SL1680 RDK

Table 4 lists the SD card related control signal configurations of SL1680 RDK.

Table 4. SD card configuration of SL1680 RDK

Signal #	Name	Description	Source
1	SDIO-MUX_SEL	0: Switch SDIO to SD Card Slot 1: Switch SDIO to M.2 WiFi	SD card Slot CDn
2	SDIO_PWR_ON	0: Power OFF SD card slot 1: Power ON SD card slot	SOC_GPIO[44]

SDIO_MUX_SEL is controlled by the **Card Detect (CDn)** pin of the SD card slot. When an SD card is inserted, **CDn** is pulled low, and the SDIO host automatically switches its connection to the SD card.

Downloaded by Anonymous () on 21 Jun 2026 04:02:27 UTC

2. References

- *Astra Machina Foundation Series Quick Start Guide* (PN: 511-001404-01)
- *Astra Machina SL1620 Developer Kit User Guide* (PN: 511-001407-01)
- *Astra Machina SL1640 Developer Kit User Guide* (PN: 511-001405-01)
- *Astra Machina SL1680 Developer Kit User Guide* (PN: 511-001403-01)
- *SL1620 Embedded IoT Processor Electrical Specification Datasheet* (PN: 505-001428-01)
- *SL1640 Embedded IoT Processor Electrical Specification Datasheet* (PN: 505-001415-01)
- *SL1680 Embedded IoT Processor Electrical Specification Datasheet* (PN: 505-001413-01)
- *SD Specifications Part 1 Physical Layer Specification Version 6.00*

Downloaded by Anonymous () on 21 Jun 2026 04:02:27 UTC

3. Revision History

Revision	Description
A	Initial release.
B	Minor update to trademarked items

Downloaded by Anonymous () on 21 Jun 2026 04:02:27 UTC



Copyright

Copyright © 2024–2025 Synaptics Incorporated. All Rights Reserved.

Trademarks

Astra Machina, SYNAP, Synaptics and the Synaptics logo are trademarks or registered trademarks of Synaptics Incorporated in the United States and/or other countries.

Android is a trademark of Google LLC. Linux is the registered trademark of Linus Torvalds in the U.S. and other countries. All other trademarks are the properties of their respective owners.

Contact Us

Visit our website at www.synaptics.com to locate the Synaptics office nearest you.

PN: 506-001588-01 Rev B

Notice

Use of the materials may require a license of intellectual property from a third party or from Synaptics. This document conveys no express or implied licenses to any intellectual property rights belonging to Synaptics or any other party. Synaptics may, from time to time and at its sole option, update the information contained in this document without notice.

INFORMATION CONTAINED IN THIS DOCUMENT IS PROVIDED "AS-IS," AND SYNAPTICS HEREBY DISCLAIMS ALL EXPRESS OR IMPLIED WARRANTIES, INCLUDING BUT NOT LIMITED TO ANY IMPLIED WARRANTIES OF MERCHANTABILITY AND FITNESS FOR A PARTICULAR PURPOSE, AND ANY WARRANTIES OF NON-INFRINGEMENT OF ANY INTELLECTUAL PROPERTY RIGHTS. IN NO EVENT SHALL SYNAPTICS BE LIABLE FOR ANY DIRECT, INDIRECT, INCIDENTAL, SPECIAL, PUNITIVE, OR CONSEQUENTIAL DAMAGES ARISING OUT OF OR IN CONNECTION WITH THE USE OF THE INFORMATION CONTAINED IN THIS DOCUMENT, HOWEVER CAUSED AND BASED ON ANY THEORY OF LIABILITY, WHETHER IN AN ACTION OF CONTRACT, NEGLIGENCE OR OTHER TORTIOUS ACTION, AND EVEN IF SYNAPTICS WAS ADVISED OF THE POSSIBILITY OF SUCH DAMAGE. IF A TRIBUNAL OF COMPETENT JURISDICTION DOES NOT PERMIT THE DISCLAIMER OF DIRECT DAMAGES OR ANY OTHER DAMAGES, SYNAPTICS' TOTAL CUMULATIVE LIABILITY TO ANY PARTY SHALL NOT EXCEED ONE HUNDRED U.S. DOLLARS.